

Enhanced stress and changes to regional seismicity due to the 2015  $M_w$  7.8 Gorkha, Nepal, earthquake on the neighbouring segments of the Main Himalayan Thrust

\*Chung-Han Chan<sup>1</sup>

1.Earth Observatory of Singapore, Nanyang Technological University, Singapore, 2.Department of Geophysics, Kurukshetra University, Kurukshetra, India

In this study we evaluate stress evolution and change in seismic hazard after the 2015 Gorkha earthquake sequence. We take a methodology usually used in areas with well-established seismic monitoring and apply it to an area with a sparse dataset and a limited time observation window. Our goal is to validate this approach as a rapid response tool for seismic forecasting after large earthquakes. We propose a long-term seismic forecasting model of the Main Himalayan Thrust using the historical earthquake catalogue and regional paleo-seismicity. Through application of the rate-and-state friction model, we evaluate short-term rate evolution after the Gorkha earthquake. The long elapsed time since the last megathrust event and the mainshock coseismic stress increase on the Main Himalayan Thrust suggest high seismic potential in the Lalitpur and Lamjung areas along the fault system. To infer rate evolution after the Gorkha earthquake, we modelled the coseismic Coulomb stress change on optimally oriented planes (OOPs). To determine regional OOPs, we used the GCMT mainshock focal mechanism to infer the regional stress orientation and assumed a low deviatoric stress for the regional stress state based on the stress estimation. As the coseismic stress impact away from the rupture patch becomes insignificant, the OOPs outside the coseismic slip patch keep the mechanism imposed by the regional stress. In contrast, the orientations of OOPs are diverse close to the rupture zone due to comparable stress magnitudes of the regional stress and the coseismic Coulomb stress change. Using the stress change on OOPs and the regional seismicity rate model through a smoothing kernel method and seismicity since 1921, we quantify the seismicity rate evolution in the region after the mainshock. The location of the consequent earthquakes coincides with areas of high background seismicity rate and areas where stress was enhanced by the  $M_w$ 7.9 mainshock and  $M_w$ 7.3 aftershock. We model the change of seismic rate over time and project a fast decrease, due to the short aftershock duration assumption we use.

Keywords: Coulomb stress change, earthquake forecasting, optimally oriented planes, the 2015 Gorkha earthquake

Testing the Coulomb stress triggering hypothesis for great subduction earthquakes using abundant focal mechanisms

Testing the Coulomb stress triggering hypothesis for great subduction earthquakes using abundant focal mechanisms

\*石辺 岳男<sup>1</sup>、尾形 良彦<sup>1,2</sup>、鶴岡 弘<sup>1</sup>、佐竹 健治<sup>1</sup>

\*Takeo Ishibe<sup>1</sup>, Yosihiko Ogata<sup>1,2</sup>, Hiroshi Tsuruoka<sup>1</sup>, Kenji Satake<sup>1</sup>

1.東京大学地震研究所、2.統計数理研究所

1.Earthquake Research Institute, Univ. of Tokyo, 2.The Institute of Statistical Mathematics

We quantitatively investigate the correlation between the static Coulomb stress changes transferred from the recent three megathrust earthquakes (i.e., the 2004 Sumatra-Andaman, 2010 Maule, and 2011 Tohoku-Oki earthquakes) and changes in seismicity using abundant focal mechanism solutions, and show that the post-seismicity is strongly affected by the stress perturbations due to the mainshocks.

To reduce the uncertainty in the  $\Delta CFF$  values due to variability in receiver faults, we calculated the  $\Delta CFF$  on the two nodal planes of the focal mechanism solutions for actual earthquakes. We used variable fault slip models inverted from tsunami waveforms for the source fault of the 2004 Sumatra-Andaman [Fujii and Satake, 2007], 2010 Maule [Fujii and Satake, 2013], and 2011 Tohoku-Oki [Satake *et al.*, 2013] earthquakes. For receiver faults, we used the focal mechanism solutions of earthquakes between January 1, 1976 and September 31, 2015 among the Global Centroid Moment Tensor (GCMT) catalog [Dziwonski *et al.*, 1981].

In evaluating the contribution of  $\Delta CFF$  transferred from the megathrust earthquakes to seismicity changes, we used median of  $\Delta CFF$  values of the 200 receiver faults in moving time window. As a result, the time series of the medians show significant positive  $\Delta CFF$  values for a while after the occurrence of megathrust earthquakes and decayed in time, while those are neutral before them for the all megathrust earthquakes. The increased median  $\Delta CFF$  values rapidly decayed to background level in case of the 2004 Sumatra-Andaman earthquake, whereas they are still elevated after 4 years in case of the 2011 Tohoku-Oki earthquake. Furthermore, the Coulomb index, a percentage of receiver faults with stress increases, at least, for one nodal plane [e.g., Hardebeck *et al.*, 1998], showed higher values in the post-seismic period than those in the pre-seismic period for the all of three cases. Our result supports the stress triggering hypothesis that the static stress changes imparted by megathrust earthquakes played a significant role in triggering seismicity changes. The conclusion is opposite from a previous study using optimally-orientated receiver faults. Hence, the present results clearly suggest the importance of considering spatio-temporal heterogeneity of receiver faults.

We repeated our analyses for three different apparent coefficients of friction (i.e.,  $\mu' = 0.0$ ,  $0.4$ , and  $0.8$ ) as well as different fault slip models (i.e., slip models by Rhie *et al.* (2007) for the 2004 Sumatra-Andaman, Delouis *et al.* (2010) for the 2010 Maule, and Yokota *et al.* (2011) for the 2011 Tohoku-Oki) in order to verify how these differences affect our conclusion. While the higher apparent coefficients of friction were more consistent with static stress triggering hypothesis, the time series of the median of  $\Delta CFF$  values showed similar patterns in most cases. The catalog dependency was also tested for the case of the 2011 Tohoku-Oki earthquake by using the F-net focal mechanisms as receiver faults.

We only considered the static stress changes transferred from co-seismic fault slips of the mainshock, while other possible factors such as the dynamic stress triggering, decreases in failure strength due to increase of pore-fluid pressure changes, postseismic slips, acceleration of plate

slip rates, static stress changes from indirectly triggered earthquakes by numerous aftershocks, and/or viscoelastic relaxation have been suggested.

Acknowledgments: This study was supported by the Observation and Research Program for Prediction of Earthquakes and Volcanic Eruptions and Special Project "Integrated Research Project on Seismic and Tsunami Hazards around the Sea of Japan" from the Ministry of Education, Culture, Sports, Science and Technology of Japan.

キーワード : Coulomb stress changes, 2004 Sumatra-Andaman earthquake, 2010 Maule earthquake, 2011 Tohoku-Oki earthquake

Keywords: Coulomb stress changes, 2004 Sumatra-Andaman earthquake, 2010 Maule earthquake, 2011 Tohoku-Oki earthquake

## 稠密地震観測による東北沖地震後の内陸誘発地震に対する応力・流体の影響の検討

Effect of stress and fluid pressure change on shallow earthquake swarm induced by the 2011 Tohoku-Oki earthquake inferred from dense seismic observation

\*岡田 知己<sup>1</sup>、中山 貴史<sup>1</sup>、平原 聡<sup>1</sup>、堀 修一郎<sup>1</sup>、佐藤 俊也<sup>1</sup>、松澤 暢<sup>1</sup>

\*Tomomi Okada<sup>1</sup>, Takashi NAKAYAMA<sup>1</sup>, Satoshi Hirahara<sup>1</sup>, Shuichiro Hori<sup>1</sup>, Toshiya Sato<sup>1</sup>, Toru Matsuzawa<sup>1</sup>

1.東北大学大学院理学研究科附属地震・噴火予知研究観測センター

1. Research Center for Prediction of Earthquakes and Volcanic Eruptions, Graduate School of Science, Tohoku University

After the 2011 Tohoku-Oki earthquake, some earthquake swarms in the inland area have been occurring. As shown in previous studies, stress change and fluid pressure change would be the causes of the earthquake swarm. Coseismic change of stress tensors is thought to be caused by the stress change due to the Tohoku-Oki earthquake [e.g. Hasegawa et al., 2012; Yoshida et al., 2012]. Diversity of focal mechanisms, which could be interpreted with the Mohr circle, suggests high pore fluid pressure [e.g. Terakawa et al., 2012]. Temporal expansion of aftershock areas suggests that the increase in the fluid pressure is the cause of the earthquake swarm [e.g. Okada et al., 2015]. For understanding more details of the induced earthquake swarm and its causes, we deploy dense seismic observation networks in three areas: southern Akita, northern Akita, Fukushima (Aizu)-Yamagata [cf. Hirahara et al., 2015, AGU Fall Meeting]. Station separation is less than a couple of kilometers in southern Akita, and about 5 kilometers in northern Akita and Fukushima-Yamagata areas. Seismometers and data loggers deployed are KVS-300 and EDR-X7000 of Kinkei System Corporation, respectively.

By using data from the dense seismic network, we can determine reliable focal mechanisms even for M<sub>l</sub> earthquakes. Focal depths of most of earthquakes are determined to be a few kilometers shallower than JMA catalog depths. The improvements of hypocenter locations and focal mechanisms will enable us to estimate the stress regime and the fluid pressure in Tohoku district in more details.

Acknowledgements:

This study was conducted with the support of the Grant-in-Aid for Scientific Research on Innovative Areas (Crustal Dynamics, KAKENHI No. 26109002) from the Ministry of Education, Culture, Sports, Science and Technology (MEXT), Japan. This study was also supported by the MEXT under its Earthquake and Volcano Hazards Observation and Research Program. Dr. Takahiro Shi'ina, Dr. Keisuke Yoshida, and Mr. Yukihiro Chiba helped us for the observation.

キーワード：2011年東北地方太平洋沖地震、誘発地震、応力、流体圧、震源メカニズム解

Keywords: The 2011 Tohoku-Oki earthquake, Induced earthquake, stress, fluid pressure, focal mechanism

余震継続時間は何にコントロールされ、確率論的地震ハザード評価にどう影響するのか  
What controls the duration of aftershocks, and why it matters for probabilistic seismic hazard assessment

\*遠田 晋次<sup>1</sup>、Stein Ross<sup>2</sup>

\*Shinji Toda<sup>1</sup>, Ross S Stein<sup>2</sup>

1.東北大学災害科学国際研究所、2.U. S. Geological Survey

1.International Research Institute of Disaster Science, Tohoku University, 2.U.S. Geological Survey

Is seismicity in slowly deforming regions such as the central U.S., Australia, and inner Honshu composed largely of aftershocks of past mainshocks, or is the rate of earthquakes steady and so indicative of future earthquake potential? While aftershock productivity grows with mainshock magnitude, aftershock duration—the time until the aftershock rate decays to the pre-mainshock rate—may not. Basham and Adams [1983] and Ebel et al. [2000] proposed that intraplate seismicity in Eastern North America could be aftershocks of mainshocks that struck hundreds of years beforehand, a view consonant with rate/state friction [Dieterich, 1994], in which aftershock duration varies inversely with fault stressing rate. Most tests of the Dieterich relationship use inconsistent duration estimates and ambiguous proxies for the stressing rate, such as mainshock frequency. Here, we estimate aftershock durations of the 2011 M=9 Tohoku-oki rupture at twelve sites up to 250 km from the source, as well the as near-fault aftershocks of eight large Japanese mainshocks, sampling faults slipping 0.01 to 80 mm/yr. We find that aftershock sequences lasted a month on the fastest-slipping faults and are projected to persist for >200 years on the slowest. If slip rate or background seismicity rate are roughly proportional to stressing rate, this supports Dieterich and Ebel's hypotheses. Thus, the hazard associated with aftershocks may depend on local tectonic conditions rather than the mainshock magnitude, and that aftershock sequences can masquerade as background seismicity, misguiding and inflating hazard assessments in some intraplate regions.

キーワード：東北地方太平洋沖地震、余震、応力伝播

Keywords: Tohoku-oki earthquake, aftershock, stress transfer

## How variable normal fault geometry affects fault interaction and stress transfer: Examples from central Apennines, Italy

\*Zoe Keiki Mildon<sup>1,2</sup>, Shinji Toda<sup>1</sup>, Gerald Roberts<sup>3</sup>, Joanna Faure Walker<sup>2</sup>, Luke Wedmore<sup>2</sup>

1.International Research Institute of Disaster Science, Tohoku University, 2.Institute for Risk and Disaster Reduction, University College London, 3.Department of Earth and Planetary Sciences, Birkbeck, University of London

Coulomb stress is routinely calculated following earthquakes in many different tectonic settings around the world to determine the transfer of stress into the surrounding crust and neighboring faults. In many of these studies, the faults modeled are of a planar geometry given by the focal mechanism of the earthquake. The coulomb stress transferred is resolved onto optimally orientated planes or planes of a defined orientation. However this is generally an inaccurate representation of active faults. Numerous observations of the surface expressions of active faults and coseismic surface ruptures from earthquakes show that they do not follow a single straight line at the surface and instead show a variable geometry (strike, dip and magnitude of offsets). It is also well established in the literature that the geometry of receiver faults greatly affects the magnitude of transferred coulomb stress. Hence the coulomb stress generated during an earthquake may be an inaccurate representation if the full variability of the fault geometry is not included. Preliminary results indicate that by including the variable geometry of the source and receiver faults, the coulomb stress pattern transferred to the receiver faults is more complex than calculated by a planar approach (Figure 1). This hypothesis is tested using the central Italian Apennines, an actively extending intra-plate region with a closely spaced, soft-linked array of faults. Holocene ( $15\pm 3$ kyr) fault scarps are well exposed at the surface due to the carbonate bedrock lithology and low erosion rate. These fault scarps show variable geometry on a range of scales, from metre to kilometre scale corrugations and variations in the Holocene throw and slip direction along the fault length. These variations are well known due to extensive fieldwork conducted in the region and good visibility of fault scarps in satellite imagery. The Italian Apennines also has an extensive historical record which is complete for magnitude  $>5.5$  earthquakes since 1349. These earthquakes can be assigned to faults with varying degrees of certainty, based on the distribution and magnitude of shaking. The effects of including variable normal fault geometry into coulomb stress calculations will be analysed using this structural and earthquake database. In particular, an earthquake sequence in 1703 where ruptures propagated from north-west to south-east is investigated, to see if the inclusion of the variable geometry can explain the sequence. Aftershocks following the 2009 L'Aquila earthquake will also be investigated to see if their distribution can be better explained by utilising variable fault geometries compared to planar faults.

Keywords: normal faulting, fault geometry, coulomb stress transfer

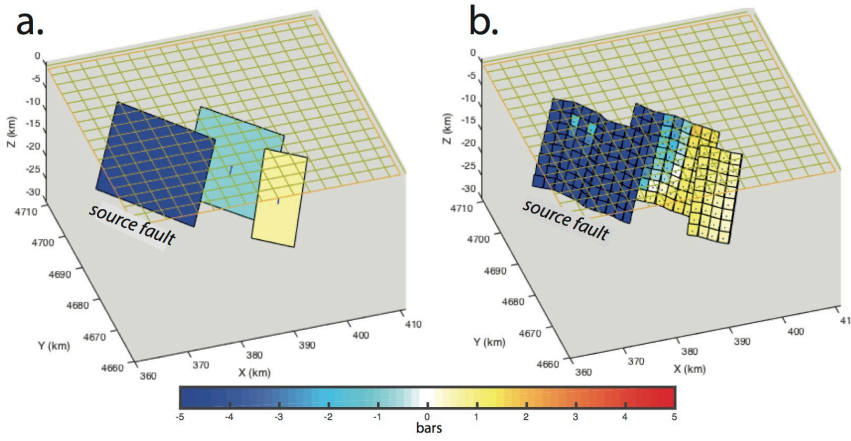

Figure 1- a.) standard *Coulomb* calculation for three planar faults. Blue indicates a coulomb stress decrease, red indicates a coulomb stress increase. b.) *Coulomb* calculation for three faults with variable geometry (strike variable). Colours as (a.). Note the complexity of the stress pattern generated for a variable geometry fault versus a planar fault.

## 付加体中の序列外スラストの活動と断層周辺の応力変化

Stress changes and the displacement of an out-of-sequence thrust in an accretionary wedge

\*宮川 歩夢<sup>1</sup>、山田 泰広<sup>2</sup>、大坪 誠<sup>1</sup>\*Ayumu Miyakawa<sup>1</sup>, Yasuhiro Yamada<sup>2</sup>, Makoto Otsubo<sup>1</sup>

1.国立研究開発法人 産業技術総合研究所、2.国立研究開発法人 海洋研究開発機構

1.Geological Survey of Japan, AIST, 2.R&amp;D Center for Ocean Drilling Science (ODS), JAMSTEC

The stress state in an accretionary wedge is one of the most important topics in subduction zone, hence fault activities are related to the surrounding stress regime in an accretionary wedge. Many study try to represent the stress state related to the fault activity in the accretionary wedge (e.g. Hashimoto *et al.* 2014; Yamada & Shibamura 2015). However, the measurement of stress in an accretionary wedge remains challenging, especially that of dynamic stress changes due to fault activity. Here we propose the stress changes associate with the displacement of an Out-of-sequence thrusts (OOSTs) by using numerical simulation. In our numerical simulation, the likelihood of fault slip around the OOST is higher before a large slip event than those after the event, suggesting that the OOST was activated during a period of high likelihood of fault slip and that the likelihood of fault slip drops after slip upon the OOST. The stress changes associated with fault activity in the numerical simulation are consistent with those reported for natural OOSTs (Otsubo *et al.* under review).

キーワード：数値シミュレーション、応力変化、序列外スラスト

Keywords: numerical simulation, stress change, out-of-sequence thrust



In-site stress estimation and evaluation in IODP expedition Site C0002, NanTroSEIZE  
In-site stress estimation and evaluation in IODP expedition Site C0002, NanTroSEIZE

\*吳 泓昱<sup>1</sup>、Chan Chung-Han<sup>2</sup>、木下 正高<sup>3</sup>、真田 佳典<sup>1</sup>

\*HungYu Wu<sup>1</sup>, Chung-Han Chan<sup>2</sup>, Masataka Kinoshita<sup>3</sup>, Yoshinori Sanada<sup>1</sup>

1.海洋研究開発機構、2.南洋理工大学、3.東京大学地震研究所

1.Japan Agency for Marine-Earth Science and Technology, 2.Nanyang Technological University,

3.Earthquake Research Institute, The University of Tokyo (ERI)

The main target of NanTroSEIZE (Nankai Trough Seismogenic Zone Experiment) is attempting to understand the stress field and stress state in the vicinity of the mega-Thrust. Until now, three IODP expeditions run for the Nankai subduction zone had accomplished. Scientific drilling vessel, Chikyu, carried out the drilling operations and collected much valuable data including LWD, core samples. Site C0002 is planned to drill over 7 kilometers to recover the fault zone material and on-site experiments data. However, the drilling operation stopped in the middle of accretionary prism because the borehole conditions and technical problems. In the stage 1, C0002A borehole was drilled from 1964.5mbrf (0mbsf) to 3336mbrf without any problem. The drilling was complete in one week on 18th October 2007. This riser-less drilling used seawater (1.03S.G) for drilling mud. In this riser-less drilling, we can observe the clear breakout in entire borehole from shallow to deep. Due to the difficulties of drillings in the following expeditions, exp.338, C0002F kept drilling 12.24-inch LWD borehole to 2005.5mbsf and abandoned at this depth by suddenly increasing wind. In the exp.348, the difficult drilling state happened in very early beginning. The sidetrack borehole, C0002P, overcame the high fractures zones and highly tilted structure to reach the center of inner accretionary wedge. Very few breakout occurred in both riser drillings, the big amount of cutting recovered indicated the weak formation collapsed and enlargement of borehole radius. In this research we try to construct the geomechanical model to explain the drilling difficulties and stress environments in the borehole. The related drilling parameters and formation compositions in these boreholes are considered as the model variables. Depending on 2-D stress model in each borehole, we combine the observation and simulated model to scope the possible stress model in the depth near the megathrust.

キーワード : NanTroSEIZE、Geomechanical model、Logging While Drilling

Keywords: NanTroSEIZE, Geomechanical model, Logging While Drilling

南海トラフ掘削トランセクトにおける応力の空間分布および日本海溝掘削との比較

Spatial distribution of stress state in the NanTroSEIZE transect and a comparison with JFAST at frontal thrust

\*林 為人<sup>1</sup>、Byrne Timothy<sup>2</sup>、木下 正高<sup>3</sup>

\*Weiren Lin<sup>1</sup>, Timothy Byrne<sup>2</sup>, Masataka Kinoshita<sup>3</sup>

1.国立研究開発法人海洋研究開発機構高知コア研究所、2.Connecticut University, USA、3.東京大学地震研究所

1.Kochi Institute for Core Sample Research, Japan Agency for Marine-Earth Science and Technology, 2.Connecticut University, USA, 3.ERI, The University of Tokyo

See English Abstract

キーワード：南海トラフ掘削、日本海溝掘削、応力

Keywords: NanTroSEIZE, JFAST, Stress

## 大深度地殻応力の測定のために提案した手法と実フィールドへの適用事例 A Proposed Method and Its Field Application of Deep Stress Measurements

\*伊藤 高敏<sup>1</sup>

\*Takatoshi Ito<sup>1</sup>

1.東北大学流体科学研究所

1.Institute of Fluid Science, Tohoku University

We have proposed a new concept in which the in-situ stress state is determined by integrating (i) the Hydraulic Fracturing (HF) method and (ii) the Diametrical Core Deformation Analysis (DCDA). The DCDA is a kind of core based method, which has been proposed recently by the authors (Funato et al., 2012, Funato & Ito, 2015), which allows us to estimate the state of in-situ stress from cross-sectional shape of boring cores. The integration leads to improve practicality and compensate disadvantages compared with the case using each data solely for the stress determination. This new concept is illustrated in Figure 1, where we assume for simplicity that the borehole is vertical and a core sample is retrieved from the same depth of the HF test interval. This new concept provides several data set available to estimate the magnitude of the maximum horizontal stress  $SH_{max}$  and its orientation in multiple ways, while the magnitude of the minimum horizontal stress  $Sh_{min}$  must be estimated only from the shut-in pressure  $P_s$  observed in the HF test. The extra data sets lead to improve practicality so much that the validity of results can be confirmed from their consistency, and they provide flexibility to determine the stress state completely, even if the data set will be missed partially.

The pressures  $P_r$  and  $P_s$  are related theoretically to  $SH_{max}$  and  $Sh_{min}$  as follows (Ito et al., 1999),  

$$P_r = (3 Sh_{min} - SH_{max})/2 \quad (1)$$

$$P_s = Sh_{min} \quad (2)$$

If the compliance  $C$  of the fracturing system is not appropriately small, the reopening pressure  $P_r$  corresponding to Eq. (1) cannot be detected by the HF test (Ito et al., 1999; 2005; 2006). It means that the magnitude of  $SH_{max}$  cannot be determined by using Eqs. (1) & (2) and the data set "a" in Figure 1. This problem can be solved by using Eqs. (2) & (3) and the data set "b" combining the core data instead of  $P_r$ . If the tensile strength  $T$  of rock can be determined using the core sample, it may be possible to roughly estimate  $SH_{max}$  from the breakdown pressure  $P_b$  which is another distinctive pressure observed in the HF test. However, it should be noted that the relationship between  $P_b$  and in-situ stresses is complicated to be changed depending on the effect of pore pressure, and it is not easy to correctly measure  $T$  at the in-situ condition. On the other hand, even if the impression packer is not available for detecting the induced fracture orientation, the orientation of  $SH_{max}$  can be estimated as that of the maximum diameter of the core sample, i.e. the data "e". The orientation of  $SH_{max}$  can be estimated also from the other stress indicators, i.e. the data "f", such as the borehole breakout (BO) and the drilling induced tensile fracture (DITF) which can be detected by the borehole wall image logging. This method was successfully applied for (i) the stress measurement in a central region of the Kumano forearc basin at a water depth of 2054 m using a 1.6 km riser hole drilled in the Integrated Ocean Drilling Program (IODP) Expedition 319 (Ito et al., 2013) and (ii) the stress measurement at a depth of about 1 km of a deviated oil well in Japan.

### REFERENCES

Funato, A., Ito, T., Shono, T. (2012). Proceedings of the 46th US Rock Mechanics / Geomechanics Symposium, Chicago, ARMA 12-588.

Funato, A. and Ito, T. (2016). International Journal Rock Mechanics Mining Sciences & Geomechanics

Abstracts, submitted.

Ito T, Evans, K., Kawai, K., Hayashi, K. (1999). International Journal Rock Mechanics Mining Sciences & Geomechanics Abstracts, 36, 811-826.

Ito, T., Igarashi, A., Ito, H., Sano, O. (2005). Proceedings of the US Rock Mechanics Symposium, Anchorage, ARMA/USRMS05-862.

Ito, T., A. Igarashi, A., Ito, H., Sano, O. (2006). Earth Planet and Space, 58, 963-971.

Ito T., Funato A., Lin W., Doan M., Boutt D. F., Kano Y., Ito H., Saffer D., McNeill L. C., Byrne T. and Moe K. T. (2013). J. Geophys. Res., Solid Earth, 118, 1-13.

キーワード：地殻応力計測、水圧破砕、DCDA

Keywords: Stress measurement, Hydraulic fracturing, DCDA

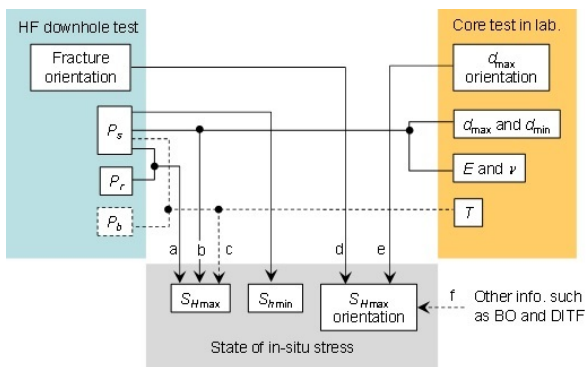

Figure 1. Procedure of stress determination in the proposed method.

A new approach to determining stress state in the crust on the basis of well data using borehole imagers

\*Dubinya Nikita<sup>1,2</sup>, Kirill Ezhov<sup>3</sup>

1.Gazpromneft STC, 2.MIPT, 3.Schlumberger

The study is devoted to the inverse problem of the stress state in the crust determination via the opportunities provided by drilling (it was developed for oil wells drilling). In particular, the proposed study introduces a methodic to define the maximum horizontal stress magnitude at the well's vicinity with high precision using the log data having the other stress state parameters known.

The basic concept of the introduced method is the relationship between the stress state of the medium and the distribution of the cracks in the material. Knowing the six independent parameters of the stress state in the medium, one is able to determine the probable spatial distribution of cracks in this material. An attempt to find a solution of the inverse problem is introduced here: in case one knows the spatial distribution of cracks in the medium it is likely to define the processes which induced these cracks and define the stress state of the area.

In case of drilling such processes might be divided into two groups: the first is closely connected to the tectonic stress state in the wide area, while the second group contains the stress alteration during the drilling process. The second group is easier to analyze as there are developed approaches to define the stress alteration. Thus once one knows the spatial distribution of cracks near the drilled well and has the drilling process analyzed, it becomes possible to get some basic information regarding the tectonic stress.

There are special logging methods known as borehole images which are sufficient to define the spatial distribution of the cracks near the wellbore. For a typical well there might be up to several thousand cracks with such information provided. Using the various types of images allows defining, which cracks are active (in terms of oil engineering it means that oil can penetrate through them). This factor plays a key role in the methodic as it was stated by the researchers of the same problem: the active cracks are in correlation with the friction properties of the medium: in fact it appears that the active cracks should all be in the area bounded by the Mohr-Coulomb failure criterion curve if using the Mohr circle.

Every crack is represented by a point at the Mohr stress diagram. Its position is determined by three principal components of the stress tensor and three angles determining its orientation relative to the stress tensor principal axes. Assuming that two principal stresses and all directions are known one can adjust the last variable (maximum horizontal stress magnitude) to move the point representing a crack. Adjusting the horizontal stresses for all cracks simultaneously (keeping in mind the general rules of continuity, equilibrium and rheology) leads to an array of points' sets representing the cracks at a normalized Mohr stress diagram. The set where all the active cracks are bounded by the Mohr-Coulomb failure criterion might be the preferable one with the maximum horizontal stress magnitude being defined. Using such a methodic allows determining the stress state near the wellbore with the lowered uncertainty (compared to other methods). The next step is to define the tectonic stresses on the basis of the stress state near the wellbore.

This methodic was successfully applied for several datasets for real oil production wells and the determined stress states were comparable with the geomechanical models for these wells and were characterized by lowered uncertainty. The methods of adjusting the maximum horizontal stress in a proper way for all the cracks and the way of considering the medium rheology are to be developed further but the mathematical models standing for these points in case of elastic medium are already

developed.

Keywords: Geomechanics, Stress state, Inverse problem, Drilling

## 鉱物脈の姿勢情報を用いた沈み込み帯地震発生域での応力および岩石強度推定：延岡衝上断層周辺付加体での例

Variations in stress, driving pore fluid pressure ratio and rock strength using orientations of mineral veins along Nobeoka Thrust, southwestern Japan

\*大坪 誠<sup>1</sup>、宮川 歩夢<sup>1</sup>、北島 弘子<sup>2</sup>、佐藤 活志<sup>3</sup>、山口 飛鳥<sup>4</sup>、木村 学<sup>4</sup>

\*Makoto Otsubo<sup>1</sup>, Ayumu Miyakawa<sup>1</sup>, Hiroko Kitajima<sup>2</sup>, Katsushi Sato<sup>3</sup>, Asuka Yamaguchi<sup>4</sup>, Gaku Kimura<sup>4</sup>

1.産業技術総合研究所 地質調査総合センター、2.テキサス大学、3.京都大学、4.東京大学

1.Geological Survey of Japan/AIST, 2.Texas A&M University, 3.Kyoto University, 4.The University of Tokyo

The crustal stresses and pore fluid pressures at depth are difficult to quantify directly, and the downhole measurements of in-situ stress are generally limited to a few km depth (e.g., Zoback and Healy, 1992, JGR 97, 5039-5057). The Nobeoka Thrust, southwestern Japan is an on-land example of an ancient megasplay fault and provides an excellent record of deformation and fluid flow at seismogenic depths. In this study, we present (1) temporal stress changes for the seismic period of the Nobeoka Thrust and (2) spatial heterogeneity of the fluid driving pressure ratio  $P^*$  by using the mineral veins around the fault zone in the Nobeoka Thrust.

The Nobeoka Thrust is a major fault bounding the northern and southern Shimanto belt of the Cretaceous-Neogene accretionary complex in Kyushu, southwest Japan. The hanging wall rock of the thrust is composed of phyllitic shales and sandstones from the Eocene Kitagawa Group, and the footwall strata of the Eocene to early Oligocene Hyuga Group are composed of a *mélange* of shale matrix with sandstone and basaltic blocks deformed in a brittle manner (Kondo et al., 2005, Tectonics 24, TC6008). The Kitagawa Group rock of the hanging wall and the Hyuga Group rock of the footwall experienced heating to maximum temperatures of about 320 degrees centigrade and about 250 degrees centigrade, respectively (e.g., Kondo et al., 2005).

Many quartz veins that filled mode I crack can be observed in the hanging wall and footwall of the Nobeoka Thrust. We applied the inversion method proposed by Sato et al. (2013, Tectonophysics 588, 69-81) to estimate stress regimes by using the mineral vein orientations. The normal faulting stress regimes are detected from the veins in the hanging wall and footwall. The orientations of stress axes estimated from the veins in the hanging wall are similar to those in the footwall. The orientation of the  $\sigma_3$ -axes in the estimated stress regime is parallel to the slip direction of the Nobeoka Thrust. The detected normal faulting stress regimes mean the post-seismic stress after the faulting of the Nobeoka Thrust.

The estimated lower bound of the maximum fluid pressure  $P^*$  are 0.16-0.19 and 0.29-0.46 in the hanging wall and footwall, respectively. The hanging wall has smaller  $P^*$  compared to the footwall in the Nobeoka Thrust. We propose the two possible explanations for the spatial variation of  $P^*$ . Firstly, the spatial variation of pore fluid pressure  $P_f$  affect directly the spatial variation of  $P^*$  around the Nobeoka Thrust. Secondary,  $P^*$  are controlled by the mechanical properties of the hanging wall and footwall. Laboratory experimental studies on rocks from the exhumed Shimanto belt along the Nobeoka Thrust indicate that phyllitic shale of hanging wall is stronger than *mélange* of footwall. The results are consistent with logging data (Hamahashi et al. 2013, G-cubed 14, 5354-5370) and the spatial variation of  $P^*$  inferred from development of mode I cracks.

キーワード：地殻応力、岩石力学特性、沈み込み帯、鉱物脈、間隙流体圧

Keywords: crustal stress, Rock strength, subduction zone, mineral veins, pore fluid pressure





## 断層応力時間変化をいかに知るかー日本の活断層の事例研究

How can we learn on time variation of fault stress state: Case histories of Japan inland active faults

\*小村 健太郎<sup>1</sup>

\*Kentaro Omura<sup>1</sup>

## 1. 防災科学技術研究所

1. National Research Institute for Earth Science and Disaster Prevention

It is an important factor to understand fault activities how the strength of a fault plane is recovered and how the stress on the fault plane accumulates during an earthquake cyclic interval. Recently, in-situ stresses associated with fault activities have been measured in and around the faults (e.g., Ikeda et al., 1996a; Ikeda et al., 1996b; Ikeda et al., 2001; Tsukahara et al., 2001; Omura et al., 2004; Yamashita et al., 2004; Lin et al., 2007; Yabe et al., 2010; Yamashita et al., 2010; Yabe and Omura, 2011; Lin et al., 2013). However, it is difficult to make clear time variation of stress state in and around a particular fault in the field because the interval of an earthquake recurrence cycle is very long (about a thousand years or more as for cases of inland active faults in Japan). An alternative way is suggested to measure in-situ stress in and around different faults that are in different stages during the earthquake recurrence intervals, and that reflect different levels of the strength recovery and stress accumulation on the fault planes. In this presentation, examples of downhole in-situ stress measurements are introduced concerning time variations of stress state.

The hydraulic fracturing method is applied to estimate stress magnitudes, assuming that one of three principal stresses has vertical direction and is equal to the overburden pressure. Because the measuring system had large compliance (i. e., large volume of water is necessary to raise pressure in measuring borehole section), the tensile strength of the borehole rock is estimated and apply to next equations:  $S_H = 3S_h - P_b + T - P_p$ ,  $S_h = P_s$ ;  $S_H$  maximum horizontal principal stress;  $S_h$  minimum horizontal principal stress;  $P_b$  breakdown pressure;  $P_p$  pore water pressure;  $P_s$  shut-in pressure;  $T$  tensile strength of borehole rock. The directions of horizontal principal stresses were estimated by observations of borehole breakouts and/or drilling mud pressure induced tensile fractures due to borehole wall imaging logging tool (BHTV borehole televiewer).

Those examples suggested that the stress on the fault plane drops in association with the earthquake and increases toward the next earthquake. However, it is not clear whether the stress increase linearly with time, or change largely just after an earthquake, or increase rapidly just before the earthquake. It is necessary to measure repeatedly in-situ stress to detect effectively the time variation of stress state in and around a fault after an earthquake.

[References]

Ikeda, R, K.Omura and Y.Iio,.H. Tsukahara, 1996a, Proc. VIIIth Int'l. Symp. on the Observation of the Continental Crust through Drilling, 30-35.

Ikeda,R., Y.Iio and K.Omura, Y.Tanaka, 1996b, Proc. VIIIth Int'l. Symp. on the Observation of the Continental Crust through Drilling, 393-398.

Ikeda, R., Y. Iio and K. Omura, 2001, The Island arc Special Issue. 10, Issue 3/4, 252-260.

Lin, W., E.-C. Yeh, H. Ito, J.-H. Hung, T. Hirono, W. Soh, K.-F. Ma, M. Kinoshita, C.-Y. Wang, and S.-R. Song, 2007, Geophys. Res. Lett., 34, L16307, doi:10.1029 2007GL030515.

Lin, Weiren, Marianne Conin, J. Casey Moore, Frederick M. Chester, Yasuyuki Nakamura, James J. Mori, Louise Anderson, Emily E. Brodsky, Nobuhisa Eguchi, and Expedition 343 Scientists, 2013, Science, 339, 687-690.

- Omura, K., R. Ikeda, T. Matsuda, A. Chiba, and Y. Mizuochi, 2004, *Earth Monthly*, extra edition No.46, 127-134.
- Tsukahara, H., Ikeda, R. and Yamamoto, K. , 2001, *Island Arc*, 10, 261-265.
- Yabe, Yasuo, Kiyohiko Yamamoto, Namiko Sato, and Kentaro Omura, 2010, *Earth Planets Space*, 62, 257-268.
- Yabe, Yasuo and Kentaro Omura, 2011, *Island Arc*, 20, 160-173.
- Yamashita, Furoshi, Eiichi Fukuyama and Kentaro Omura, 2004, *Science*, 306, 261-263.
- Yamashita, F., Mizoguchi, K., Fukuyama, E. and Omura, K., 2010, *J. Geophys. Res.*, 115, B04409, doi:10.1029 2009JB006287.

キーワード：応力、断層、水圧破碎、ボアホールブレイクアウト

Keywords: stress, fault, hydraulic fracture, borehole breakout

## Strain localization in accretionary prisms.

\*Arthur Bauville<sup>1</sup>

1. Department of Mathematical Science and Advanced Technology, JAMSTEC

Plate motion varies smoothly (over ~100 km) but results in localized (m to km scale) deformation near plates interface. Strain localization is caused by local stress variations and/or the response of the material to it. Generally, the localization of strain can have two different causes:

(1) A rheological cause, here termed dynamic strain localization. Thereby, strain in a homogeneous material becomes localized because the material softens in certain regions during the deformation (strain softening) due to processes such as grain size reduction, brittle precursor controlled fluid-rock interaction or shear heating.

(2) A structural cause, here termed kinematic strain localization. Thereby, the initial strength of the deformed region is heterogeneous and strain localizes due to initial differences in mechanical strength and/or due to particular geometries. Such localization of strain can occur in linear viscous materials.

Kinematic strain localization is still incompletely understood and may have a major importance (1) in subduction zones, where high sea floor topography is correlated with low plate coupling, i.e. large magnitude earthquakes are less likely to happen; (2) in fold-and-thrust belts where the geometry of the former margins can control the distribution and emplacement of tectonic nappes. Here I present the results of 2D numerical simulations that demonstrate the importance kinematic strain localization on the structure of fold-and-thrust belts and accretionary prism. Early results towards a scaling law between sea floor topography, stress concentration and strain evolution are also presented.

Keywords: strain localization, accretionary prism

## Stress and Kinematic Evolution of the Hoping Area, northeastern Taiwan

\*En-Chao Yeh<sup>1</sup>, Chao-Yan Lin<sup>1</sup>, Wei-Cheng Li<sup>1</sup>, Sung-Yang Huang<sup>2</sup>, Tai-Tien Wang<sup>3</sup>, Weiren Lin<sup>4</sup>, Wayne Lin<sup>2</sup>, Cheng-Ku Lin<sup>2</sup>

1.Department of Earth Sciences, National Taiwan Normal University, Taipei, Taiwan, 2.Green Energy and Environment Research Laboratories, Industrial Technology Research Institute, Hsinchu, Taiwan, 3.Institute of Mineral Resources Engineering, National Taipei University of Technology, Taipei, Taiwan, 4.Kochi Institute for Core Sample Research, Japan Agency Marine-Earth Science and Technology, Kochi, Japan

Taiwan is an active mountain belt located at the conjunction between the Eurasian Plate and Philippine Sea Plate. Due to the subduction flip and the southwestward propagation of Okinawa Trough, the northeastern Taiwan is also influenced by the back-arc extension, besides convergence. Therefore, the study at NE Taiwan provides insights into understanding the stress, kinematic and structural evolution of mountain building processes.

According to fault slip inversion and cross-cutting relationship on the core examination of 600m metagranite and field observation, the sequence of structure development associated with stress change in Hoping region is identified as: (1) regional foliation and early quartz veins in reverse faulting stress regime with SE-NW compression; (2) pseudotachylite in normal faulting stress regime; (3) flattened structure; (4) kink in strike-slip faulting stress regime with N-S compression; (5) fault slip in strike-slip faulting stress regime with SE-NW compression; (6) open filling fluid conduits and calcite veins in normal faulting stress regime with NE-SW extension. Synthesizing the structure characteristics associated with stress field, tectonic meanings of each structure in terms of structural evolution in the Hoping region can be interpreted. The stress field of regional foliation is reflective of oblique compression between Eurasian and the Philippine Sea Plates. Pseudotachylite and flattening structure may represent evidence of syn-tectonic extension. SE-NW compression inferred from kink bands may correspond to the back-arc extension of Okinawa Trough but the compression of oblique collision still can not be ruled out. NE-SW extensional environment of normal faulting stress regime is appeared, consistent with in-situ stress assessment. The finding of pattern of kinematic and stress evolution of structural development compatible with focal mechanism results from local seismic network shed lights on evaluating the stress evolution with time.

Keywords: stress evolution, kinematics, mountain belt, Taiwan

## Evolutionary model of oblique-rifting basin : Insights from discrete element method

\*I-Wen Cheng<sup>1</sup>, Kenn-Ming Yang<sup>1</sup>, Jong-Chang Wu<sup>2</sup>

1.National Cheng Kung University, 2.CPC Corporation, Miaoli, Taiwan

The geometry of oblique-rifting basin is strongly related with the angle ( $\alpha$ ) between the trend of rift and that of regional major extensional stress. The main purpose of this study is to investigate characteristics of geometry and kinematics of structure and tectono-stratigraphy during the evolution of oblique-rifting basin. In this study, we simulated the oblique-rifting basin model of various  $\alpha$  with Particle Flow Code 3-Dimensions- (PFC-3D). The main theory of PFC-3D is based on the Discrete Element Method (DEM), in which parameters are applied to every particle in the models. We applied forces acting on both sides of rift axis, which  $\alpha$  are 45 , 60 , 75 and 90 degrees , respectively, to simulate basin formation under oblique-rifting process.

The study results of simulation models indicated that: 1. the en echelon faults in the rifting basins are sub orthogonal to the trend of major extensional stress; 2. the density of en echelon faults in rift basins decreases gradually when  $\alpha$  is close to 45 degrees ; 3. in these models, the  $\alpha$  angles, which are 45 , 60 , 75 and 90 degrees, correspond to the angles of 0, 15 -20 , 25 -30 and 50 -60 degrees between the rift trend and en echelon faults trend. According to the simulation results, the possible directions of major extensional stresses during the formation of oblique-rifting basin can be speculated.

Keywords: oblique-rifting basin, discrete element method, PFC-3D